

PRODUCT INFORMATION PACKET



Model No:
Catalog No: FEH1026SU
1/4 HP, 1075 RPM, 460V, 48FR, CENTURY HEATMASTER ULTRA MOTOR
Condenser Fans



Regal and Century are trademarks of Regal Beloit Corporation or one of its affiliated companies.
©2019 Regal Beloit Corporation, All Rights Reserved. MC017097E





Nameplate Specifications

Output HP	1/4 HP	Output KW	0.19 kW
Frequency	60 Hz	Voltage	460 V
Current	0.9 A	Speed	1075 RPM
Service Factor	1	Phase	1
Duty	Air Over	Insulation Class	F
Frame	48	Enclosure	Totally Enclosed
Overload Protector	Automatic	Ambient Temperature	80 °C
UL	Recognized	CSA	Y
CE	N		

Technical Specifications

Electrical Type	Permanent Split Capacitor	Starting Method	Induction Run
Poles	6	Rotation	Reversible
Mounting	Extended Studs	Motor Orientation	Any
Drive End Bearing	Ball	Opp Drive End Bearing	Ball
Frame Material	Rolled Steel	Shaft Type	Double Flat
Overall Length	12.12 in	Frame Length	4.12 in
Shaft Diameter	0.500 in	Shaft Extension	6.5 in
Outline Drawing	FEH1026SU-S01	Connection Diagram	614131-242

This is an uncontrolled document once printed or downloaded and is subject to change without notice. Date Created: 10/14/2019

GENERAL INFORMATION:

SHAFT RUNOUT: .001 [.03] T.I.R. PER INCH LENGTH OF EXTENSION

BEARINGS: BALL

MOUNTING POSITION: ALL ANGLE

ELECTRICAL DATA:

OVERLOAD PROTECTOR: AUTOMATIC RESET (T.I. 7AM 304)

LINE LEADS: NO. 18 GA., .06 [1.5] THK. XLP 125°C INSUL.

REVERSING PLUGS: NO. 18 GA., .03 [.8] THK. XLP 125°C INSUL.

GROUND LEAD: NO. 18 GA., .03 [.8] THK. (GREEN) INSUL.

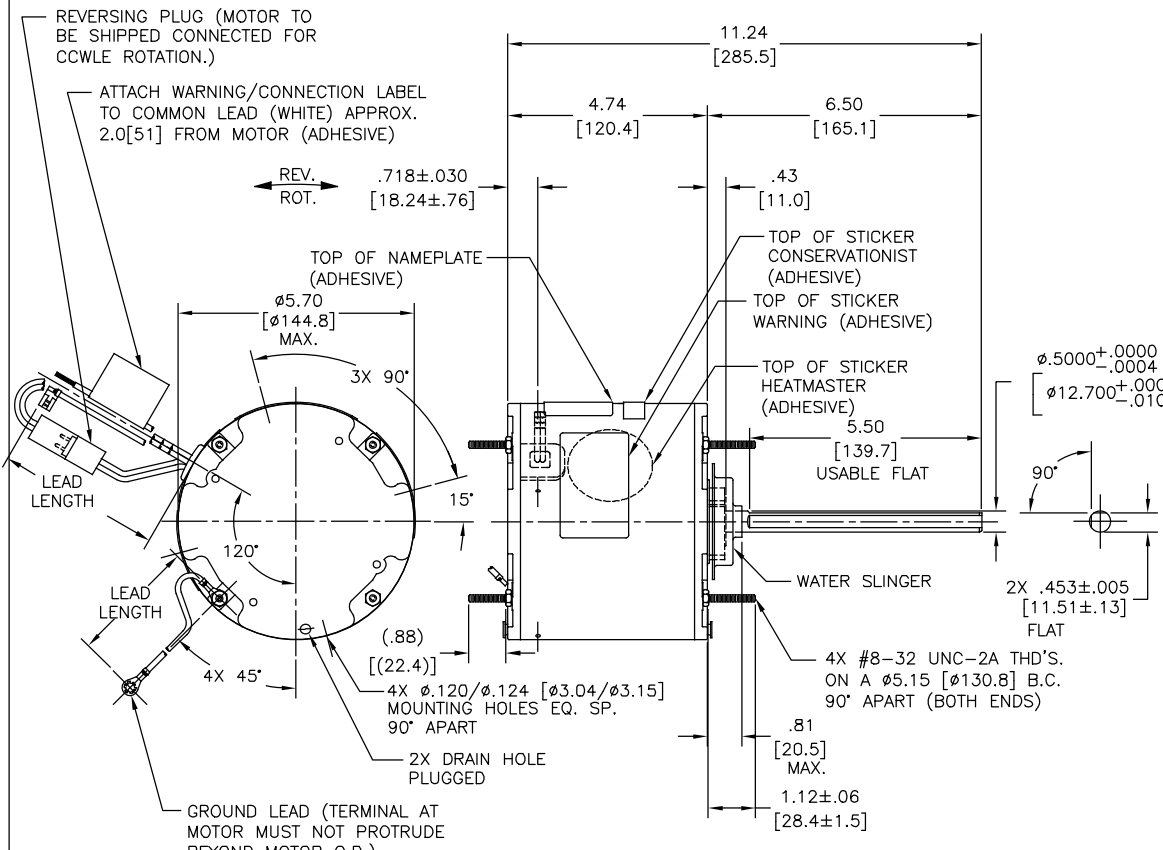

NAMEPLATE DATA:	EXTERNAL CONNECTION DIAGRAM
MODEL NO.: F48AF29A01 CUST. P/N: FEH1026SU HP: 1/4 ROT.: REVERSIBLE RPM: 1075 TYPE: UF FRAME: 48 VOLTS: 460 PH: 1 AMPS: 0.9 HZ: 60 INS.: F AMB.: 80°C DUTY: AIR OVER CAP.: 7.5 MFD/370 V ENCL: ENCLOSED UL LOGO CSA LOGO THERMALLY PROTECTED	SEP. CAP. BROWN BRN/WHT WHITE BLACK LINE ROTATION BLACK BLACK WHITE WHITE CCWLE BLACK WHITE WHITE BLACK CWLE 614131-242

PERFORMANCE CURVE NO.	TORQUE @ 1075 RPM (25°C)	APPROVED SAMPLE	UL COMPONENT FILE #	CCN #	CSA FILE #	CLASS #
C32582	28.8 OZ. FT.		E46412	PRGY2	LR43341	4211-01

COLOR	LENGTH	TERMINAL OR STRIP LENGTH
GREEN (GROUND)	12.0/13.0 [305/330]	#10 EYELET
BLACK/WHITE	3.0/5.0 [76/127]	REVERSING PLUG
BROWN	48.0/51.0 [1219/1295]	.25 [6.4] FLAG
BROWN/WHITE	48.0/51.0 [1219/1295]	.25 [6.4] FLAG
WHITE	48.0/51.0 [1219/1295]	.50 [12.7] SKIN
BLACK	48.0/51.0 [1219/1295]	.50 [12.7] SKIN

REGAL-BELOIT CORPORATION (RBC) PROVIDES TECHNICAL ASSISTANCE TO OUR CUSTOMERS IN SEVERAL AREAS. SINCE RBC DOES NOT RECEIVE ALL DATA CONCERNING THE USE AND APPLICATION OF THE MOTOR, THE SUITABILITY OF THE MOTOR FOR THE APPLICATION MUST BE DETERMINED BY THE CUSTOMER.

DIMENSIONS WITHOUT TOLERANCES ARE FOR REFERENCE ONLY.

MAIN FRAME - OLE	ENCLOSED
END FRAME - OLE	ENCLOSED
MAIN FRAME - LE	ENCLOSED
END FRAME - LE	ENCLOSED

- NOTES:
- ATTACH INSTRUCTION SHEET 69P9-3 ONTO SHAFT APPROX. 1.0[25] FROM WATER SLINGER
 - 4X SCREWS 6159B2-001 & 4X HEX NUTS 7555A19H01 & 4X SCREWS 13833003 TO BE PUT IN A POLYBAG.

DRAWING REVISION	REVISION BY	DATE
D	GELINE ZHAO	05-23-2019
ECO	KEYUN QONG	05-23-2019

LEAD DATA

ENCLOSURE

THIRD ANGLE PROJECTION

DRAWN BY: N.HONG	DATE: 01-18-2013	Regal Beloit America, Inc.
APPROVED BY: D.ZHANG	DATE: 01-18-2013	
PROCESS/FINISH	MATERIAL	DESCRIPTION: MODEL-RFHP-48FR OUTLINE
SIZE: C	DWG NO: FEH1026SU	SHEET: 1